



3500kg



MAIN FEATURES

Excellent hydraulic pump unit for low maintenance

Heavy duty steel construction with epoxy powder coated finish to give greater ant-corrosion resistance.

Three position trigger Lifting-neutral-Lift.

Polyurethane double fork rollers and wheels fitted as standard.

Entry/exit rollers on the forks for easy pallet entry/exit.

Extra long forks

TUV/GS approved and CE Rated.

Other fork sizes are available for this model from 800mm to 3000mm long and 450mm to 685 wide

Spare parts available From stock

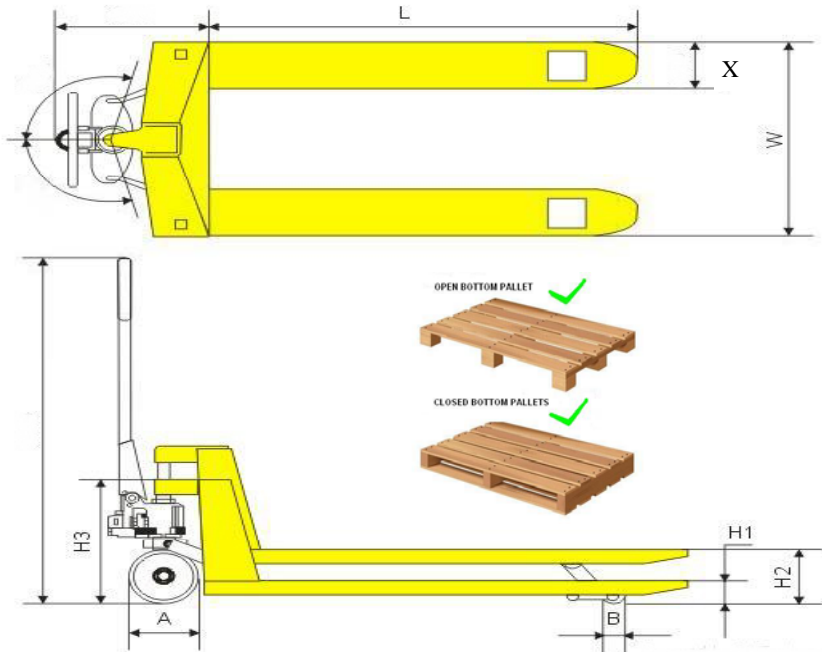

MODEL	ACL35		
Capacity		kg	3500
Min fork height	H1	mm	85
Max fork height	H2	mm	200
Steering wheel size	A	mm	200x50
Fork roller size	B	mm	80x70
Fork width	X	mm	160
Fork length	L	mm	2000
Width	W	mm	540
Steering		°	205°

MIDLAND PALLET TRUCKS LTD

Part of the Midland Group of Companies

Building 33 Second Avenue, Pensnett Trading Estate, Kingswinford

West Midlands. DY6 7UG

Telephone 01384 841440

Fax 01384 841450

Email. sales@midlandpallettrucks.com

