



MAIN FEATURES

Excellent hydraulic pump unit for low maintenance

Heavy duty steel construction with epoxy powder coated finish to give greater ant-corrosion resistance.

Heavy duty lift table with 500kg Capacity

Polyurethane wheels fitted as standard complete with break

Ideal for lifting and transporting a variety of goods

TUV/GS approved and CE Rated.

Other table top sizes available to order

Spare parts available From stock

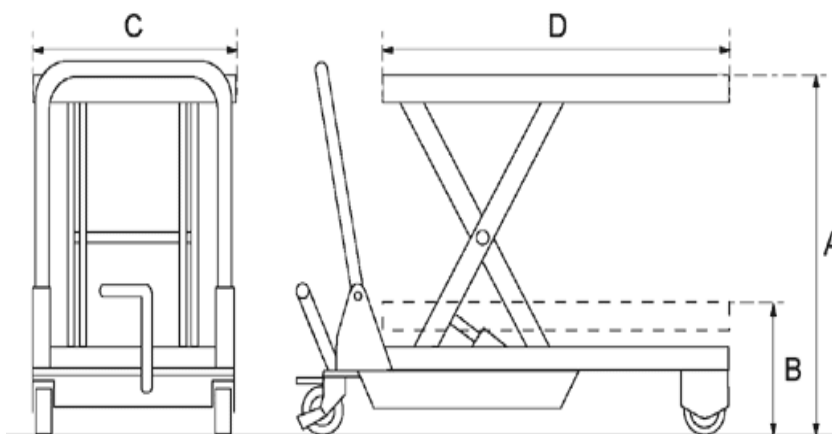

MODEL		TF50
Capacity	kg	500
Min table height	B	mm 340
Max table height	A	mm 880
Table dimensions	C,D	mm 850(D)x500(C)x50
Caster wheel	mm	125x40
Foot pedal cycles to max height		27
Weight of unit	kg	81
Height of handle from ground	mm	990